

Audio Processing Theory

How to improve the FM stereo coverage

Oscar Bonello, AES Fellow Member, Solidyne Labs, Buenos Aires

NOTE: This is a white paper. The definitive paper is published as "Multiband audio processing and its influence on the coverage area of FM stereo transmission" at **Journal of the Audio Engineering Society**, New York, March 2007 (www.aes.org)

This paper describes the Psychoacoustics theory involved in the design of state of the art digital Multiband Audio Processors used for AM & FM broadcasting transmission. It analyzes how the average rms value of the audio signal can be improved without losing audio quality. In the second part, it will be demonstrated that the audio processing increases the coverage of FM stereo transmission.

0-INTRODUCTION

During many years, several techniques for audio processing have been used to increase the modulation of the transmissions for AM and FM broadcasting and several articles were published on that matter.

In the case of AM transmissions, it has been demonstrated, long ago by O. Bonello [1], that the audio processing increases the average level of the audio, allowing us to predict the increasing of the coverage, on the basis of the improved power at sidebands.

The digital audio and the use of powerful DSP's for audio processing has refined the techniques of the multiband processors, obtaining a very solid and pleasant sound; fulfilling in addition its main objective: to increase the average level of the modulation. Nevertheless, the basic principles of design are kept like jealous secret.

A very important aspect is the study of the coverage of the FM transmissions. It is due to the fact that the power of a FM signal does not depend on the modulation level, but that always is constant, being its amplitude. In addition, the sidebands of the FM have a very complex behavior that does difficult to obtain valid conclusions. Like result of these statements, many communications engineers believe that in FM broadcast, the audio processing lacks the advantage of increasing the reach of the radio station. That conclusion is opposed to the experience of the audio engineers, at the FM stations, that know by practical experience, that the installation of a good audio processor allows improving the coverage area, although they are not clear about the reasons for which this happens.

In this state of affairs, the objective of the present work is to clarify with scientific foundations, the concept of the increasing of the RMS value of the modulation and its influence in the reach of stereo and mono FM transmitting.

1- INCREASING THE RMS VALUE OF THE MODULATION

Fig.1 shows a simplified blocks diagram of a multiband audio processor (digital or analog). The number of bands usually varies from 3 to 6. The audio signal comes with pre-emphasis and passes through band filters, usually of 18 or 24dB/octave. Each band is compressed with high slope compressors. The radio engineer selects the attack and recovery times of each band, to optimize the sound.

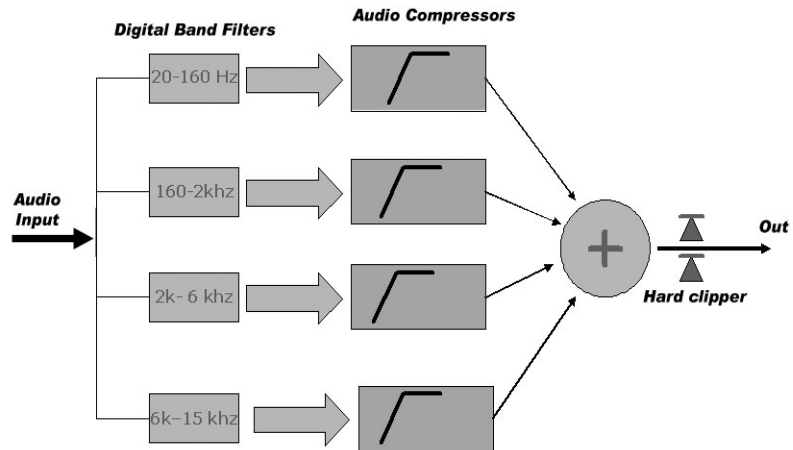

FIG 1 Block Diagram of multiband compressor

At first glance, it can be noticed that when compression is done, in separated bands, it is possible to obtain a high density of sound, because each band adjusts its level for maximum signal. This concept is related to the *loudness* of a program signal.

It is a classic concept of psychoacoustic science, related to the form in which in the internal ear, more indeed in the basilar membrane, the *cilias* and its corresponding nervous terminals are excited. This excitation distributes by frequency bands on the membrane forming a kind of *biological spectral analyzer*. Each one of the musical notes excites a certain zone on the basilar membrane.

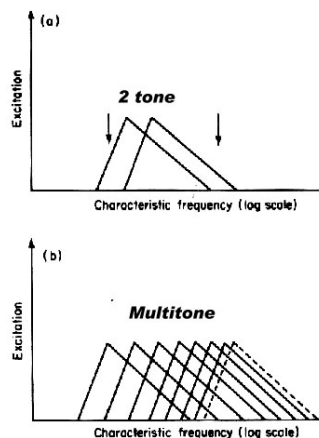

FIG 2 Excitation of the basilar membrane

The Fig.2 shows the excitation produced by two tones. This represents a typical situation when a person listen a musical theme in which two predominant bands exist.

If this audio signal is compressed in several bands, the audio level of each band increases, as show the Fig.2 at bottom, managing a greater excitation of the membrane, that the ear associates with a sound of greater loudness.

This explains some of the results that are obtained with the multiband compression. But in order to increase the RMS level, another stage of process is needed: an audio clipper. This is because the audio program has a random distribution of amplitudes. Impulses of very short duration can be at 20 dB peak above the average RMS. But the FM standards indicate that the maximum modulation, still in short peaks, does not have to exceed the 100%. Then, the most effective method to increase the RMS value is eliminating by clipping the peaks of very short duration. The clipping concept naturally is associated to distortion, being absolutely rejected into any stage of the high quality audio chain. Nevertheless, in broadcasting, the clipped signals have a long tradition, due to the necessity to obtain high values of modulation. Throughout the years, the audio R&D engineers have created several techniques to reduce the undesirable effects of the clipping, maintaining the psychoacoustic advantage of obtaining a greater excitation at the basilar membrane. These techniques have been developed empirically and rarely have deserved a theoretical explanation. It will be analyzed, the way in which the ear perceives the distortion derived from the clipping of a sine wave signal.

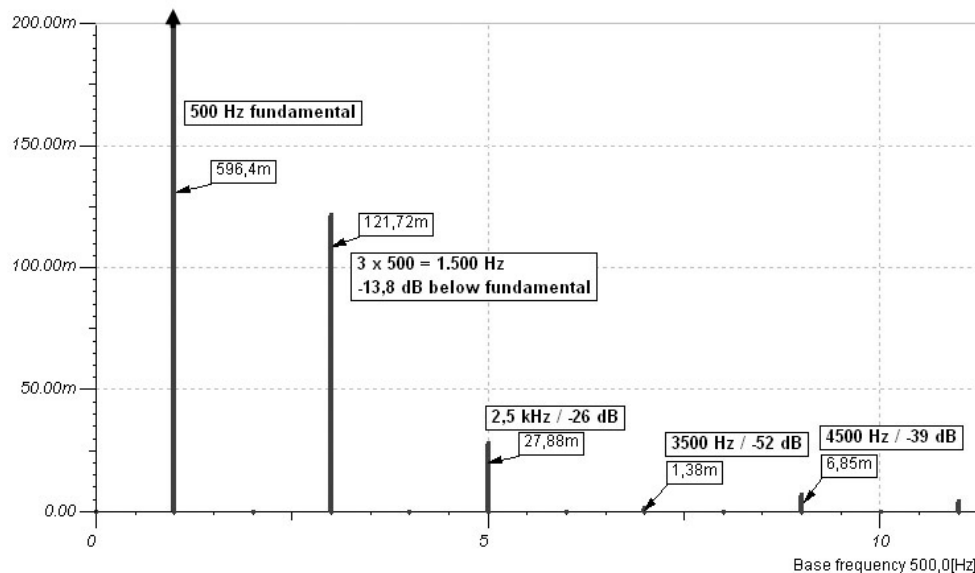

FIG 3 500 Hz, 6 dB clipping, harmonic spectrum

Fig.3 shows the harmonic spectrum of a 500 Hz sine wave, with 6 dB of soft clipping. In order to analyze the audibility of this distortion, it will be considering the masking effect.

In Fig.4 is represented the clipped signal and the masking that the 500 Hz tone produces. The procedure of masking calculation used, is the proposed by Terhardt et al [2] whose results come very near the real masking curves, measured by other authors. It can see, at first glance, that the masking doesn't improve the situation, because the distortion is perfectly audible. That is to say that the distortion produced by a single musical note, sustained in the time and clipped by 6 dB, would be audible.

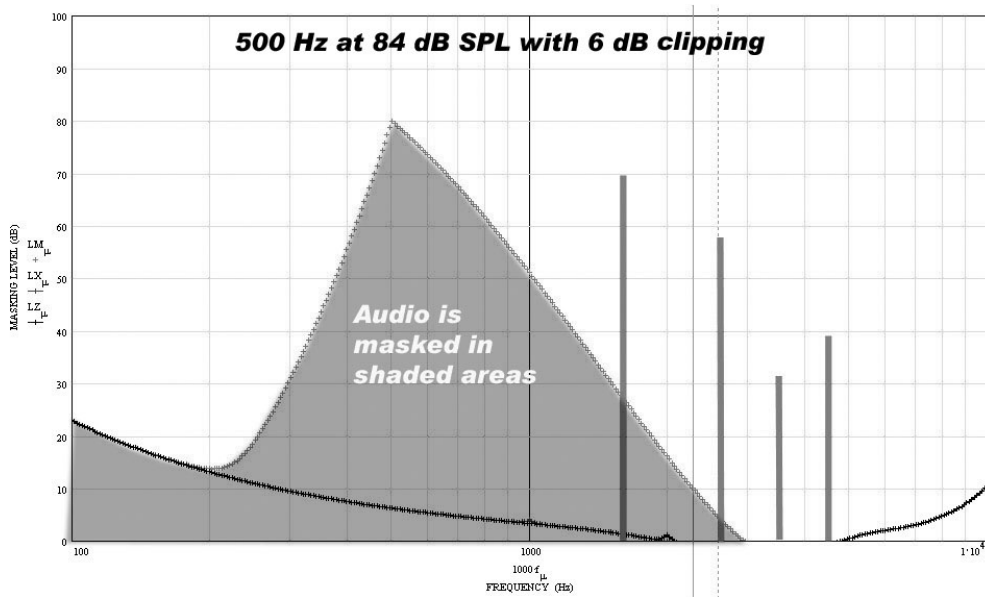

FIG 4 Harmonics of the 500 Hz clipped wave

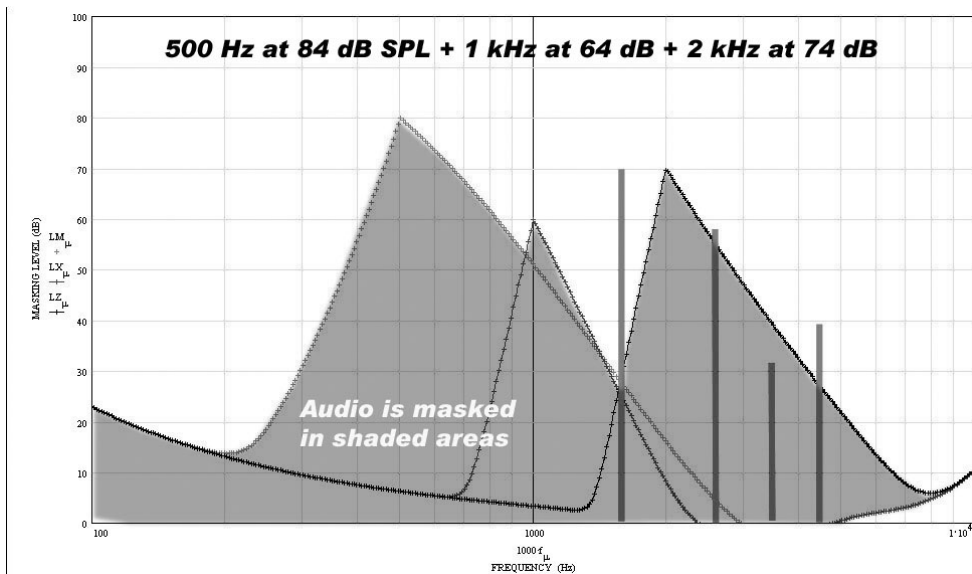

FIG 5 Masking 500 Hz clip, when 3 bands are present

Nevertheless, it has other factors that improve the situation. When being complex sonorous material (music or word), the multiband compression increases the spectral energy of the adjacent bands. Fig.5 shows the effects of add two frequency bands with a separation of one and two octaves, with levels of 10 and 20 dB below a main band of 500 Hertz. Note that the undesired overtones generated by the clipping are partially masked. If the 3 bands are taken to the same level (Fig.6) by means of even greater compression, all the components, except the 3rd harmonic, are masked and therefore they are not listened. It can be seen that, based on the type of program, and the compression, it is possible to reduce the distortion produced by a severe clipping. Obviously, if the program material lacks energy in spectral zones next to the clipped signal, it is not possible to use

this technique. Or said otherwise: with this type of program (i.e. a piano or a clavichord) a clipping of 6dB will be audible.

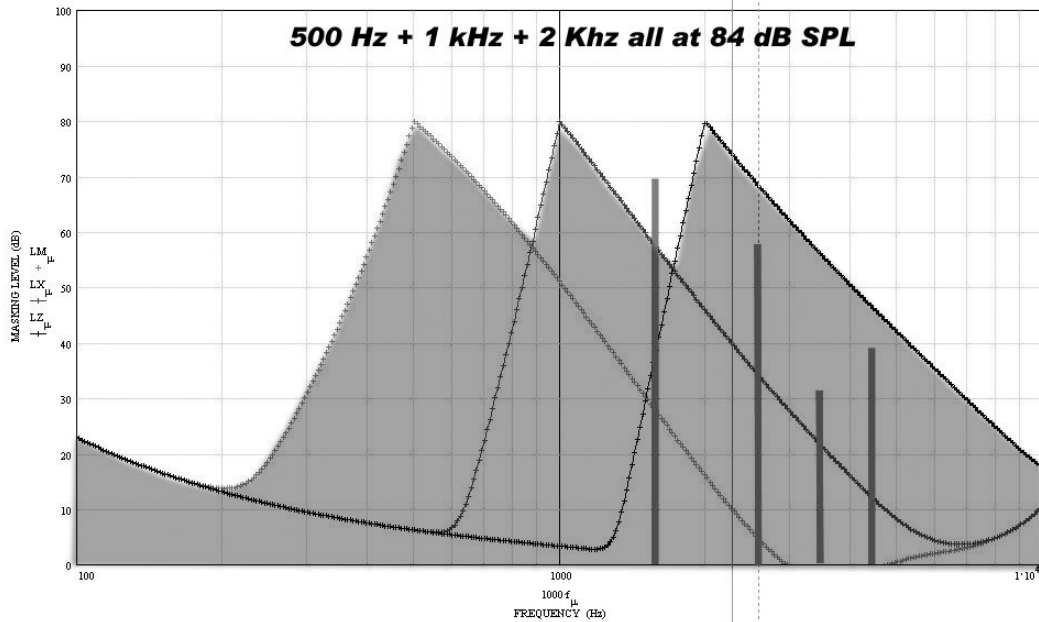

FIG 6 Masking 500 Hz clip, with 3 bands, at the same level

The preceding analysis does not consider one of the important advances that the modern audio processors incorporate: the control of the time duration of the clipping. Let return to the Fig.1 and analyze the action of the compressors based on the time. Imagine that the compression threshold agrees almost exactly with the threshold of the clippers. If, in addition, the attack times are instantaneous, the clipper will never work. But in real AM/FM audio processors, the times of attack are considerably slow and different for each band (and user modifiable). This way, when the processor is tested with a sine wave, it never appears the clipping. But if it is tested with a burst signal, for example a 50 ms burst of 1 kHz, it can be seen that the first cycles are clipped and soon, when the compressor reaches its final value, the clipping disappears. This means that the system clips the peaks of very short duration, avoiding the clipping of peaks of considerable duration, in order of not affecting the audio quality. This last statement deserves a detailed analysis.

The perception of the distortion during short intervals differs from the analysis in continuous running, given by the masking theory before seen. During very short intervals, is compromised the capacity of the brain to solve the information that from the internal ear arrives by 30,000 nervous fibers. In the case of a computer that solves the Fourier transformation, it must be computed N samples within a temporary window (T_n). The required time to make the calculations, is the delay necessary to obtain the spectrum data.

In the case of the brain, the "biological computer" also requires a certain time to transform data into a sensorial perception. This means that when a tone is mixed with harmonics, the brain needs some time to interpret the exact *timbre* it has (or if a pure sine wave is heard or a distorted one). This psychoacoustic phenomenon produces a type of special masking denominated Burst Masking, that has been studied by O.Bonello [3]. This masking is applied to the recognition of a short duration tone of audio in the presence of another burst of more intense tone, of very different frequency (to be outside the zone of masking in permanent regime).

It can be seen in Fig 7 a curve, taken from [3], that summarizes the results of the statistical study. The subjects listen alternatively a burst of N milliseconds of the masking tone and a burst of the

same tone plus a second tone or noise. The curves of Fig.7 indicate the limit level, below that the second tone is unable to be recognized.

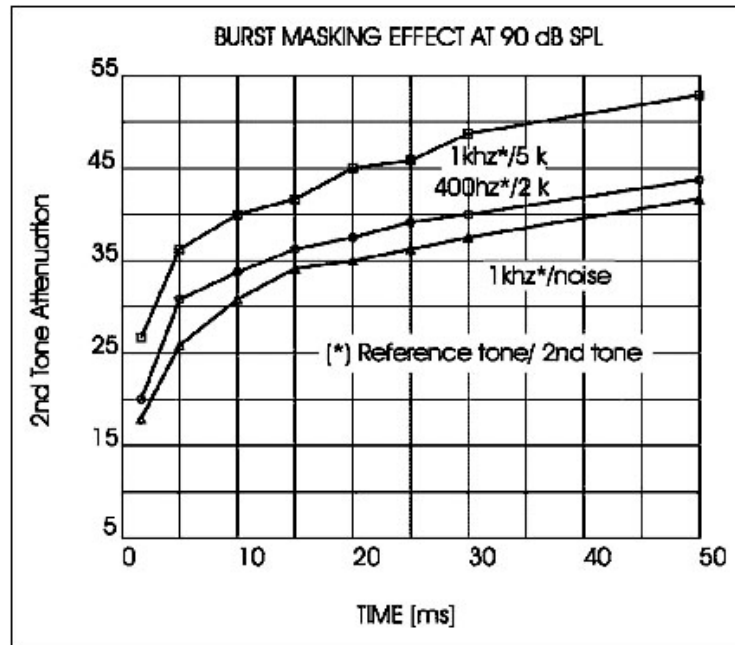

FIG 7 Burst Masking, from O.Bonello [3]

For example, if a masking curve (static) is applied to a pure tone of 1 kHz at 90dB SPL, it can be found that is possible to recognize a tone of 5 kHz, 65 dB below the tone of 1 kHz. But the upper curve of Fig.7 (1 kHz/5 kHz) shows that within a burst of 50 ms this value is reduced to 53 dB and for 5 ms it is only 36 dB. The concept of *Burst Masking* helps us to understand, in a scientific way, why reason changing the attack times of the multiband compressors, it is possible to reduce, or even eliminate, the audibility of the clipping distortion, keeping the advantage of increasing the RMS value of the audio signal.

1.1 Example

It must be observed that the action of the static masking is very low, for 3rd harmonic, but is definitively important for 5th harmonic and up, that are responsible for the rough sound due to the clipping. The third harmonic, however, adds a timbre to the original sound that modifies it slightly, but in a natural way, without causing discomfort to the ear. Let us imagine, for example, a signal that is clipped 30 %. Watched in an oscilloscope, it would be described as a very severe clip. Nevertheless the calculation of Fourier indicates that 5th harmonic and the successive ones are below 40 dB of the fundamental one. In conditions of permanent listening this value is perfectly audible (remember that the threshold for static masking was -65 dB). But applying the curves of the burst masking (Fig.7) it can be seen that for 10 ms there are 40 dB of masking that make inaudible such severe clipping.

This explains, for the first time, the reason by which in numerous tests of hearing, the listeners have defined the broadcast processed sound of *better quality* than the original one, because the ear perceives a greater loudness, without perceiving an increase of the distortion.

1.2 IM cancelled clipper

A later refinement is added to the new designs of audio processors for FM: the clipper with intermodulation cancellation.

In order to understand it better, remember that the FM transmission is made emphasizing the high frequencies over 2,122 Hz; according to a RC constant of 75 μ S (50 μ S in Europe). This means to accentuate 17 dB at 15 kHz before the transmission. This idea was brilliant in 1930 decade, when it was invented, and it allowed the reduction the background noise (hiss) at the FM transmissions. The idea was to take advantage of the fact that music and voice have low octave-band levels of signal, over 5 kHz and the pre-emphasis allowed to increase them, taking advantage of the modulation capacity of FM transmission. But at that moment, the 78 rpm recordings, the music and the human voice, had very attenuated the high frequencies due to the limitations of the recording processes and the acoustic characteristics of the musical instruments and voice. Still during the fifty following years this idea remains valid. The LP recordings and the tape recorders, shares a strong limitation to the maximum levels they can manage at 15 kHz. Even with the creation of new musical styles, like Rock music, the measurements demonstrate attenuations from 15 to 20 dB in 16 kHz octave, referred to the octave of 1 kHz, as R.Cabot et al, demonstrated [4]. This caused that the after pre-emphasis signal, maintains the content of high frequencies below the mid frequencies one.

This situation changes from 90's due the use of music synthesizers and the massive use of the digital recording in CD: a support with capacity to give the full signal level up to 20 kHz. This new improved capacity was used by the phonographic industry to give recordings with contents of high frequencies unusually elevated.

The strong presence of high frequency tones, recorded with the new CD technologies; changes the balance maintained during 50 years, which made possible the pre-emphasis in FM.

At first glance, a new FM standard must be set, to replace the old pre-emphasis. But the possibility of modifying a standard that is used in hundreds of million FM receivers around the world, is not a feasible scenario. Therefore, the new generation of audio processors must accept that the audio material, after the pre-emphasis, contains, sometimes, more signal at the high frequency bands that in mid bands.

This means, at first glance, that the 100% modulation level would be set at 15 kHz. But doing so, the mid notes would be of lower level, and the loudness of the radio would be lost, which would be unacceptable.

The only solution, facing this new scenario, consist in compress/limit the bands of high frequency until equaling them with the mid bands. Nevertheless, the compression reduces the loudness of the high frequencies, because reduces the level of all the frequencies of that band (for example from 8 to 15 kHz). Therefore only a small part of the excess of high frequency signal is compensated with compression. Most of the signal is clipped. This can sound as a blasphemy among the purists of the perfect sound; but certainly is tolerated by the ear, under certain circumstances. It must be considered that most of the clipping happens over 5 kHz. If the clipper is carefully designed it only has odd harmonics distortion. For example, clipping 5 kHz the first component appears at 15 kHz, at the end of the band. Over 5 kHz is possible to clip without audible consequences, because the third harmonic falls outside the band of FM audio. This begins to solve a very important problem. Nevertheless, when several high frequencies tones are clipped simultaneously, it appears in addition to the harmonic components (non-audible), intermodulation components (audible).

In order to reduce the problem of the IM distortion, caused by high frequency clipping, different circuits, based on the principle of Fig.8, are used. This dual clipper has a high frequency channel with a 2 kHz splitter. After the clipper there is a high-pass filter (for example at 900 Hz) that does not affect the frequency response below the clipping threshold. Nevertheless this filter prevents the

passage of the components of intermodulation produced by the high frequency's clipper. The later mixer restitutes the full audio spectrum. A second clipper works on the full spectrum. The clipping threshold of the first clipper is generally different from the second, depending on each designer the relation chosen between both. In some cases the second clipper is located within the stereo coder, working over the MPX signal. A suitable balance between both clipping levels obtains that the listener perceives excellent trebles, although occasionally heavy clip of high frequencies, in some musical passages, usually not perceived at all.

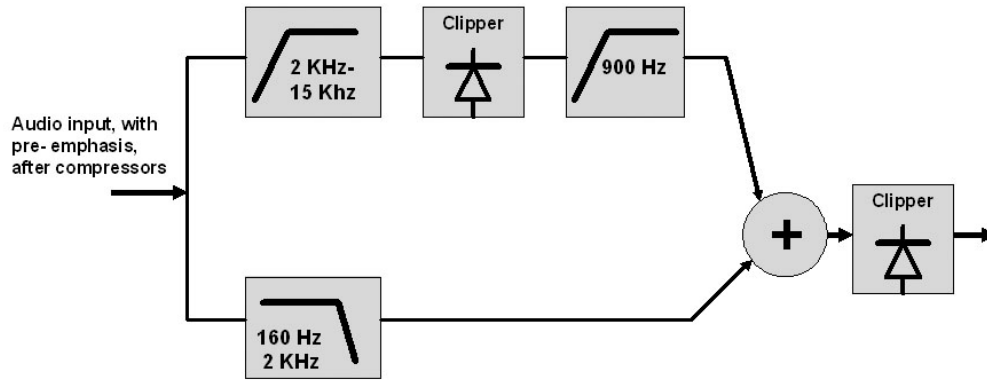

FIG 8 Dual bands IM cancelled clipper

It is important to notice that most of the processors today are based on digital systems with DSP units, in where the different parts are not identifiable because they are created by software. This does not modify, of course, the concept elaborated through the diagram blocks that have been seen.

2- Coverage area of a processed FM transmission

After the analysis of the technology involved in a broadcasting audio processor, it will be studied the increase of the coverage area of a station due to the processing of audio. In this analysis, it will not be included any psychoacoustic consideration. Only it will be admitted that beyond the auditory sensation of greater loudness, there are measurable elements like the increase of the rms level of the audio signal.

The measurement technique proposed in [1] today is used in Modulation Monitors, so that the engineer of the radio station can exactly evaluate the increase at the rms value, that produces certain adjustment of parameters at the audio processor. This data is important, because it is directly related, with the covered area of the station.

It will be analyzed first the simpler case: the AM transmission

A carrier of amplitude **E** and frequency **fc**, modulated by a sine wave of frequency **fm** and amplitude **m**, can be expressed by [5]:

$$e(t) = E \cdot \sin \omega_c t + \frac{E \cdot m}{2} \cdot \sin(\omega_c + \omega_m)t + \frac{E \cdot m}{2} \cdot \sin(\omega_c - \omega_m)t \quad (\text{EQ-1})$$

$$E \cdot \sin \omega_c t$$

Being:

Is the value of the carrier, which **do not** transport information. It is therefore a lost power that therefore it will not take into consideration.

Taking both final terms from Eq-1 it will have:

$$e_{(lat)} = \frac{E.m}{2} \cdot \sin(\omega_c + \omega_m)t + \frac{E.m}{2} \cdot \sin(\omega_c - \omega_m)t$$

Being $e_{(lat)}$ the signal due only to lateral bands

The RMS power, on sidebands, that this signal develops on the antenna of impedance **Ro** is:

$$2P_{lat} = \frac{e(t)^2}{Ro} = \frac{(E.m)^2}{4Ro} + \frac{(E.m)^2}{4Ro} = \frac{(E.m)^2}{2Ro}$$

The power without modulation, due only to the carrier signal, is:

$$P_0 = \frac{1}{2} \frac{E^2}{Ro}$$

Replacing the value P_0 of the previous equation, the power in lateral bands $P_{(lat)}$ is:

$$P_{lat} = \frac{1}{2} P_0 \cdot m^2 \quad \text{EQ-2}$$

Being **m** the modulation factor, that can vary from zero to one, given by:

$$m = \frac{\% \text{ Modulación}}{100}$$

And **P₀** the power of the carrier, without modulation

It can be seen that EQ-2 indicates clearly that the effective radiated power, on which depends the coverage of the AM radio, is proportional to **P₀** and to the square of **m**. This indicates that having a average value of **m=0,2** and a **P₀** power of 10 KW, the effective power in sidebands will be 200 W. If now the audio is processed, to maintain a average value **m=0,4** the power raises to 800 W and the coverage will increase. It can be seen from another point of view, because lowering the power of the transmitter to 2.5 KW it can be obtained the same coverage that with 10 KW and the audio signal without processing.

These results are well- known for many years and are the reason for which the AM radio stations have been leaders in the technologies of the audio processing.

But in FM the things are not so simple. The fact that the power of a FM signal keeps always constant, unlike the one of AM, has made suppose many engineers who the reach of a transmission of FM does not benefit with the increase of the average rms modulation.

Let analyze a signal modulated in FM. It can be described as [5]:

$$e(t) = E_c \sin(\omega_c t + \frac{\Delta f}{f_m} \sin 2\pi f_m t)$$

Being E_c the amplitude of the carrier of frequency $\omega_c = 2.\pi.f_c$

f_m is the modulation frequency.

In the FM signal a new element appears; the modulation index m given by:

$$m = \frac{\Delta f}{f_m} = \frac{\text{Frequency Deviation}}{\text{Modulation Frequency}}$$

As well, it is important to introduce in the analysis the concept of Percentage of Modulation, $M\%$, given by:

$$M\% = \frac{\Delta f}{75\text{KHz}} . 100$$

With $M\%$ varying between 0 and 100 % and depending on the audio signal and the audio processing.

This is due to the fact that a commercial transmission of FM uses a maximum deviation (100 % of modulation) of 75 kHz.

And therefore it can be replaced:

$$m = \frac{\Delta f}{f_m} = \frac{M\% . 75 \text{ KHz}}{100 . f_m} \quad \text{EQ-4}$$

EQ-4 joints both factors that deserve our analysis: $M\%$ (it depends on the processing) and f_m (modulating frequency)

The solution of the EQ-3 requires the use of Bessel functions Type-I. Unlike the simple resolution of the signal modulated in AM, the FM requires of tens of terms (strictly speaking, infinites), reason why influence so much the modulation index, and the modulation frequency. This great complexity has motivated the difficult to understand the flow of sidebands power and their relation with the modulation. Some results, in graphical form, can be seen in [5] and [6] that give an idea of the complex way in which the numerous sidebands of FM interact.

In order to be able to analyze the way in which the energy of a FM signal flows, it will be discarded the power of the carrier that does not transport information

The level of the carrier, for different modulation index, is given by:

$$e_0(t) = E_c (J_0(m) . \sin \omega_c t) \quad \text{EQ-5}$$

Being:

$e_0(t)$ is the carrier based on the time

E_c is the level of the carrier without modulation, m = modulation index

J_0 = Bessel function Type-I, order zero for value m

For this analysis it will make an important simplification that is the key to obtain a comprehensible result. It will be noticed that the functions of Bessel are orthogonal; this means that the sum of the squares of its terms is equal to one. In mathematical terms:

$$[J_0(m)]^2 + 2\sum_{i=1}^{i=\infty} [J_i(m)]^2 = 1 \quad \text{EQ-6}$$

As the total power of a FM signal is always constant (being it its amplitude), the EQ-6 indicates that when modulating the carrier, the energy of the sidebands is taken from the energy of the carrier. This affirmation allows for a simplified calculation of the energy in the sidebands, because the sidebands energy can be obtained from the total power minus the carrier power (EQ-5), then:

$$P_{lat} = P_o(1 - (J_0(m))^2) \quad \text{EQ-7}$$

Being ***P_{lat}*** the power on the sidebands, ***P_o*** the power of the transmitter
m = modulation index (depends on the modulation frequency and the audio processing level)
J_o = Function Bessel Type-I, order zero for value *m*

The next step is to graph the EQ-7 to obtain conclusions. Now, it will be analyzed the power output in sidebands *P_{lat}*, based on the modulation index, taking in mind that the EQ-4 relates ***m*** to the modulating frequency and the modulation index

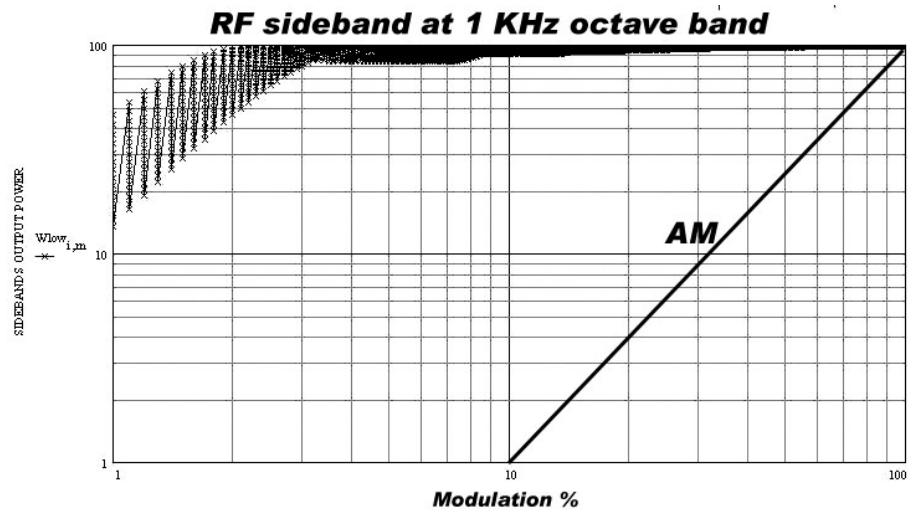

FIG 9 FM modulation sidebands at 1 kHz octave band (707-1414 Hz) for 100 W FM transmitter, compared with a 200 W AM transmitter.

In Fig.9 it can be seen a graph of the EQ-7 for a 100 W FM transmitter. The graph shows a great number of modulating frequencies within the octave of 1 kHz (707 Hertz - 1414 Hertz)

X-axis represents the values of modulation *M*% from 1 % the 100%, given by the Eq-4, and the Y-axis the power output in sidebands, on which the reach of the radio depends, from 1 W to 100W

As reference, it have been included in the same graph the EQ- 2 (marked AM) that represents the behavior of an 200 W AM transmitter, that is independent of the modulating frequency. For AM transmitter, a 200 W carrier power was selected in order to get the same sideband power at 100 % modulation, that the 100 W FM transmitter

The great difference between AM and FM can be seen. In 200 W AM transmitters a 45% of modulation is required to get 20W sideband output power at the 100 W AM transmitter. This indicates the importance of audio processing in AM due to the improvement of sidebands power with the modulation percentage. Contrary, in FM, is enough 1 % modulation to get 20W of sidebands

power. What means this? Very simple: that in a mono FM transmission the audio processing do not contribute to the increase of the RF power. That is to say that audio processing will increase the loudness of the audio on the air, but it will not increase the coverage area.

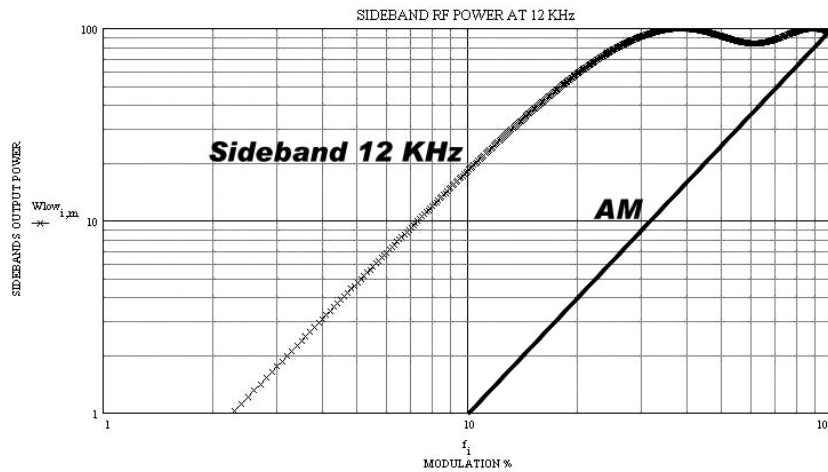

FIG 10 FM sidebands at 12 kHz modulation

What happens for high modulation frequencies? It can be seen in Fig.10 the behavior of a signal of 12 kHz transmitted in FM mono. The situation has only a minor change, that still do not offer important advantages. In fact, with 10% of modulation already obtain 20W and with 30% of modulation the maximum power output is reached.

2.1 Coverage in Stereo FM

The stereo signal is obtained by means of a sub-carrier of 38 kHz modulated in amplitude by the component L-R. If this 38 kHz sub-band arrive weak at the receivers, background noise and distortion is generated; that it prevents the comfortable reception. In general terms, the noise in the sub carrier of 38 kHz means the end of the coverage area of a Stereo FM station.

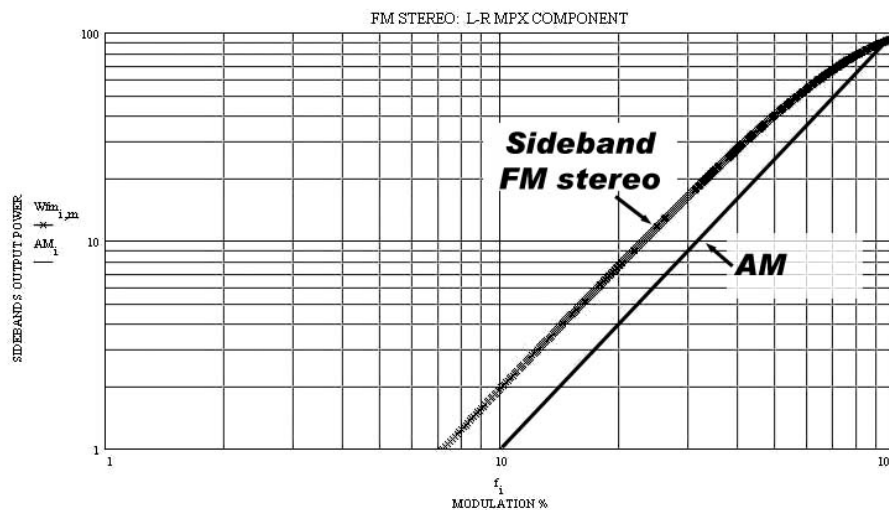

FIG 11 FM stereo sidebands at 38 kHz sub carrier

It can be seen at Fig.11 the behavior of the EQ-7 when a 38 kHz sub carrier is sent. Now is clear a remarkable approximation to the values of AM; which indicates that the increase of the RMS value of the modulating audio signal also will increase the power in sidebands and therefore the reach of the radio in FM Stereo. Now, for the first time, it appears the phenomenon noticed in empirical way by the FM stations engineers that usually was considered like a legend by many communications engineers.

Considering that the frequency band to transmit in FM is from 30 to 15,000 Hz, and then the sub carrier of 38 kHz must have a bandwidth of 38 kHz +/- 15 kHz. Representing again the EQ-7 for the full band between those ends, obtains Fig.12. The shaded area represents the bandwidth of transmission up to 15 kHz. All the audio material will fall within this band. Therefore, the behavior of the complete transmission will depend on the power applied to the worse point of this band that corresponds to its bottom edge. Is interesting to observe that the sidebands power transference, based on the modulation, **is almost exactly equal in AM and Stereo FM**, for an AM transmitter of twice the power of the FM one.

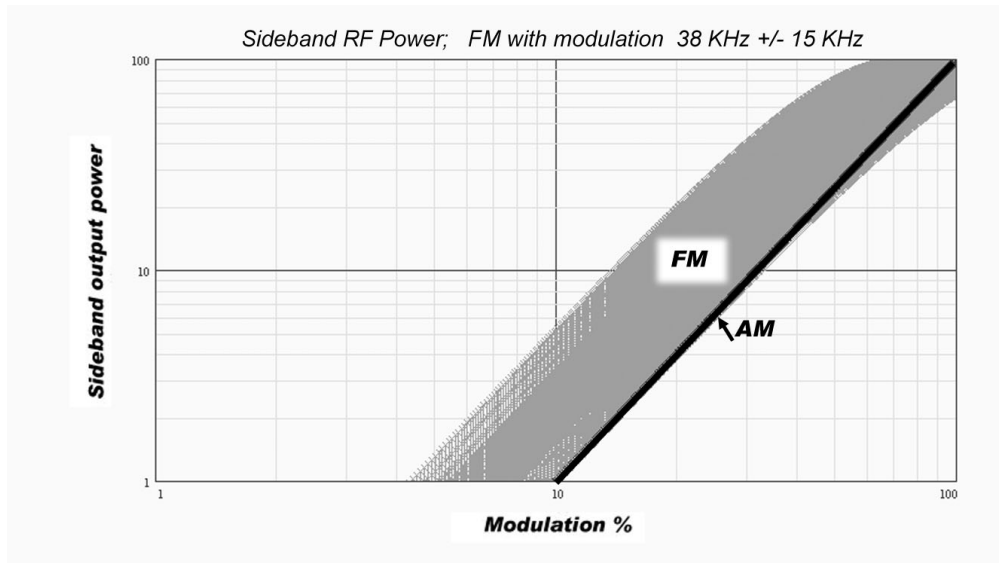

FIG 12 FM stereo with MPX modulation 30-15.000 Hz

Nevertheless, it is possible to ask if this result is some mathematical anomaly or can be really verified in field measurements, made in scientific and careful way.

For this issue, it is recommended to analyze the work of Torick-Keller [7] who made careful measurements with the intention of verifying the increase of the coverage of a transmitter of FM Stereo located in Meriden, Connecticut. In this test, the modulation average at the 38 kHz sub carrier was increased to values of 95 %, by means of a very extreme audio processing. The results of this work indicate that it is possible (for those extreme values of sub carrier modulation) to increase up to 4 times the area covered with a stereo FM station. Then, it can be seen that the measurements of Torick-Keller coincides with the predictions of the Fig.12, although the increase of the RMS values obtained by means of high quality multiband processing are far from the 95% obtained by the authors. A main difference is the use of very high compression in the Torick-Keller experience and an expander system at the receiver side, for dynamic range restoration. In the kind of multiband processors described in this paper, the modulation of the 38 KHz subcarrier never reaches 95 % as in Torick-Keller system does. Then is not necessary the expander at the receiver. From measurements done by the author in about 25 radio stations, the average modulation of the 38 kHz sub carrier were in the order of 25 to 40 %, depending on the audio processor settings. . The improvement over the non-processed audio signal was in the range of 2 to 6 dB. Then, the measured field coverage area reported was improved about 20 to 60 % (that is a distance

improvement of 9 % to 26 %). This value depends on the processor settings that must be a tradeoff between audio quality and coverage.

3 Conclusions

It has been analyzed the present state of the psychoacoustic theory that involves the design of the digital audio processors for broadcasting. And the reasons for obtaining an important increase in the loudness of the audio and in the RMS modulation values, with a minimum audible degradation of the sound quality. This apparent degradation is, nevertheless, compensated by the sensation of high loudness and high impact bass that causes that a high proportion of the audience considers the processed sound like better than the original one.

Finally, analyzing the sidebands of the transmission, considering the orthogonal property of the Bessel functions, it has been able to demonstrate that in FM Mono, the coverage do not increase with the audio processing. Contrary, in FM Stereo, an important increase of the sidebands radiated power occurs, showed at Fig.12, which allows predicting the real increase of the coverage of a transmission, knowing the increase of the RMS value of the modulation, due to audio multiband processing.

4 References

[1] Oscar Bonello "New improvements in audio signal processing for AM Broadcasting" , AES Journal Vol 24 #5, June 1976

[2] E.Terhardt, Gerhard Stoll and M.Seewann, "Algorithm for extraction of pitch and pitch salience from complex tonal signals" Journal of Acoust.Soc.Am. Vol 71 pag 679, March 1982

[3] Oscar Bonello, Burst Masking, "Enmascaramiento por Rafaga", EAA Symposium of Architectural Acoustics and Iberian Congress on Acoustics, Madrid, Spain, October 2000, ISBN 84-87985-03-3

[4] R.Cabot, R.Genter II and T.Lucke, "Sound Levels and Spectra of Rock Music", AES Journal Vol 27, # 4, April 1979

[5] R.Landee, D.Davis and A.Albrecht, "Electronic Designers Handbook" Section 5.1-5.32, MacGraw-Hill Book, New York 1957

[6] National Association of Broadcasters "Engineering Handbook", Sixth Edition, pp 427 – 474

[7] E.Torik and T.Keller, "Improving the signal to noise ratio and coverage of FM stereo broadcasts", AES Journal Vol 33 # 12, December 1985