

(* *) HEADPHONES LEVEL (Installed on the studio desktop)

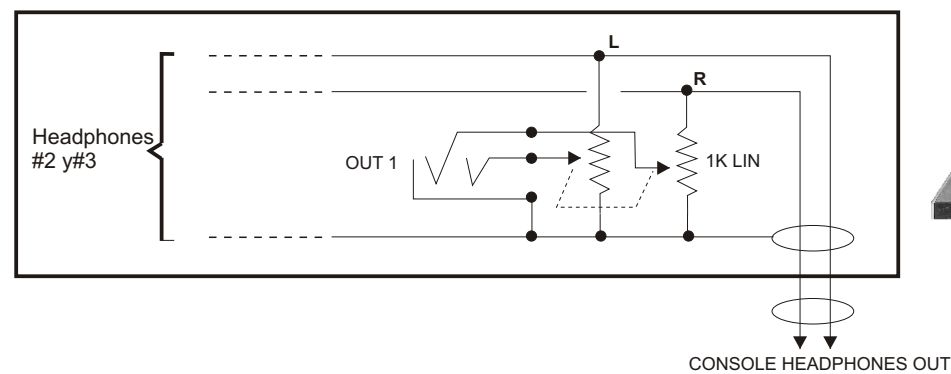

CONNECTION FOR INDIVIDUAL LED ON MIC

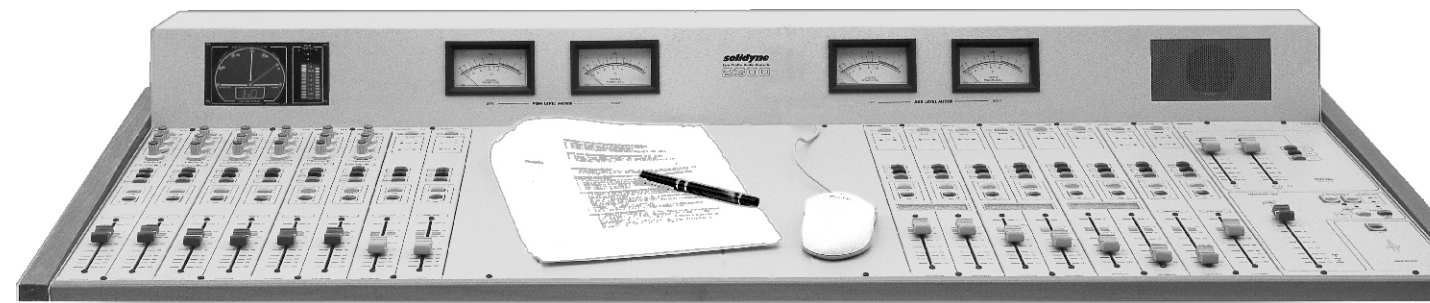
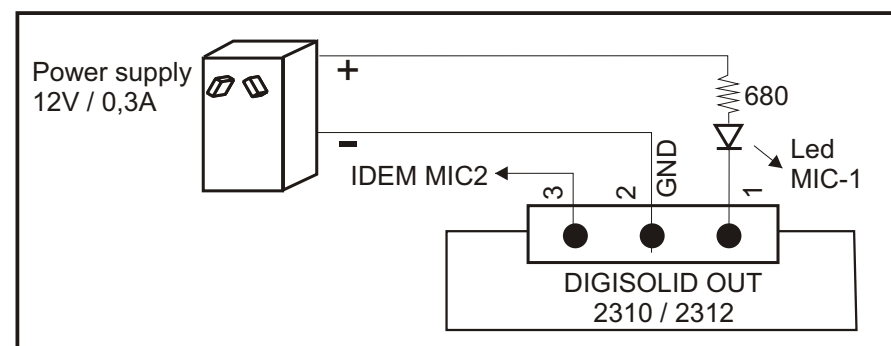

Ferrite O-Rings

If RF fields exists inside the studios, they can produce humming in the console. If it occurs, is strongly recommended that all audio cables does have ferrite o-rings of diameter 60mm (2 1/2 inches).

General connection's diagram